

SpinWarrior

Rotary Encoder Controller for USB

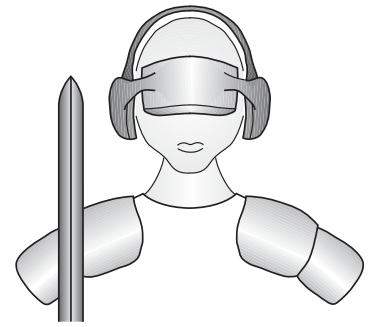

Code Mercenaries

1. Features

- USB interface
- USB V1.1/2.0 compliant low speed device
- USB HID 1.1 compliance
- To be used with electromechanic or electrooptic quadrature encoders
- 3 encoders plus 6 inputs (SW24A3)
- 4 encoders plus 7 switches (SW24R4)
- 6 encoders plus 3 switches (SW24R6)
- Encoder signal frequencies up to 5kHz (SW24A3, single channel)
- For motion tracking or human input
- Enable line for encoders to reduce power consumption in sleep mode
- Single +5V power supply
- Available in DIL24 and SOIC24 package

1.1 Variants

SpinWarrior is available in three variants. Custom modifications are possible for production volumes.

SpinWarrior24A3

- 3 encoders plus 6 digital inputs
- 16 bit absolute position tracking

SpinWarrior24R4

- 4 encoders plus 7 switches
- 8 bit relative position tracking

SpinWarrior24R6

- 6 encoders plus 3 switches
- 8 bit relative position tracking

2. Functional overview

SpinWarrior is a USB HID device of the generic type. This means it will be handled by the HID driver on almost all recent operating systems, but no higher level driver (like a mouse driver) will grab the device and block the direct access.

SpinWarrior reports the axes as standard HID axes and the buttons as standard HID buttons. So higher level functions like the HID Manager on MacOS X can preprocess the data without problems.

SpinWarrior

2.1 Product selection matrix

Type	Encoders	Switches	Abs/Rel	Index Impulse	max. Freq.	DIL24	SOIC24
SpinWarrior24A3	3	6 (no debounce)	Abs	√	3900Hz (5000Hz single channel)	√	√
SpinWarrior24R4	4	7	Rel	-	3500Hz	√	√
SpinWarrior24R6	6	3	Rel	-	2500Hz	√	√

SpinWarrior

3.0 Pin Configurations

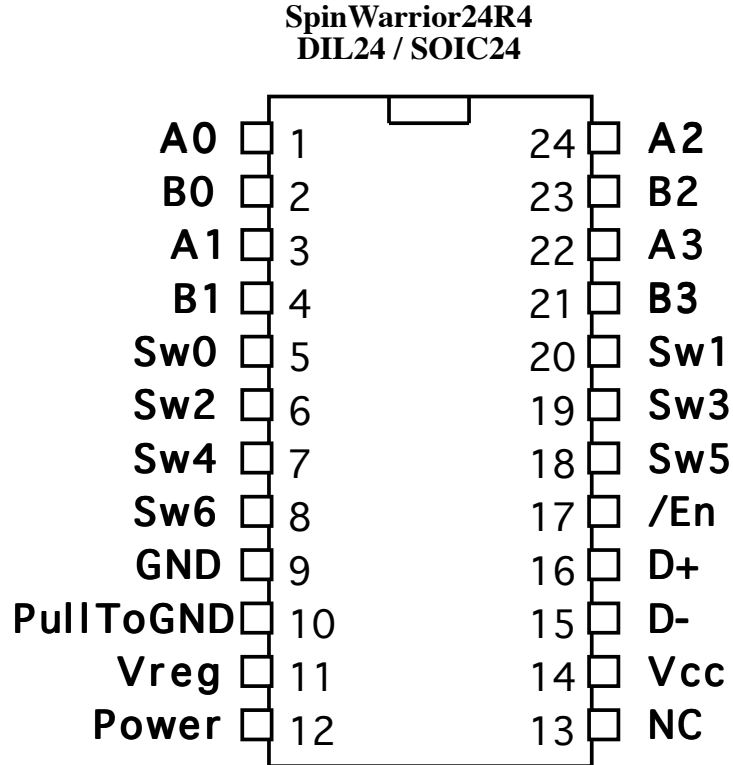
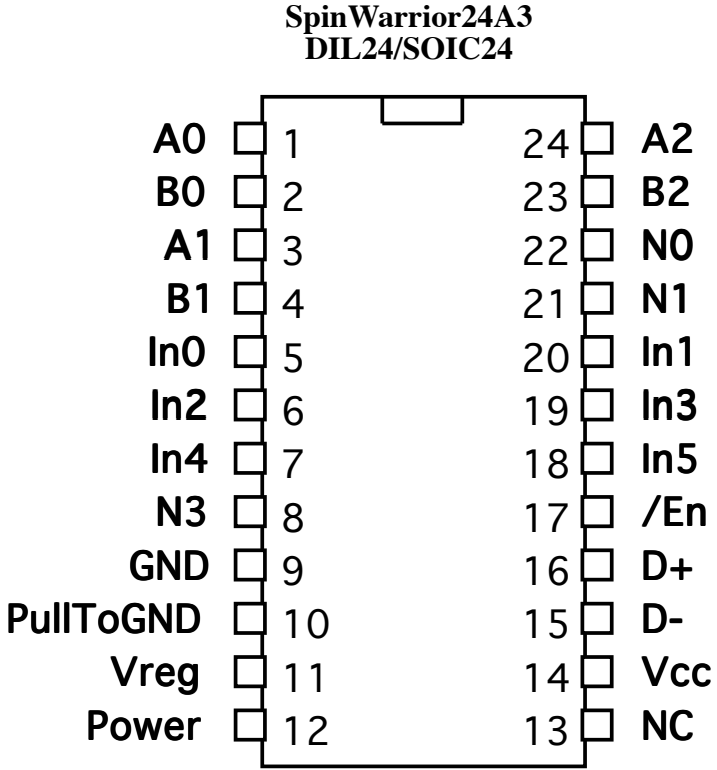

All drawings: TOP VIEW!

SpinWarrior

SpinWarrior 24R6
DIL24 / SOIC24

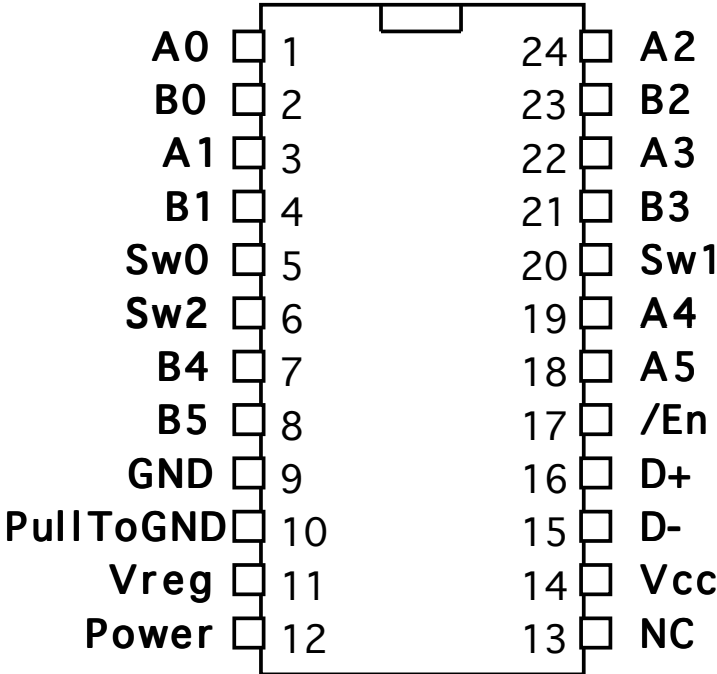

All drawings: TOP VIEW!

SpinWarrior

4.0 Pin Descriptions SpinWarrior 24A3

Name	I/O	Type	Pins	Description
D+, D-	I/O	special	16, 15	USB differential data lines
A0, B0	I	Input, internal pullup	1, 2	Quadrature signals for X axis encoder
A1, B1	I	Input, internal pullup	3, 4	Quadrature signals for Y axis encoder
A2, B2	I	Input, internal pullup	24, 23	Quadrature signals for Z axis encoder
N0, N1, N2	I	Input, internal pullup	22, 21, 8	Index inputs for the encoders
In0, In1, In2, In3, In4, In5	I	Input, internal pullup	5, 20, 6, 19, 7, 18	Digital inputs, active low
/En	O	OpenDrain, internal pullup	22, 21	Enable signal for encoders. Encoders can draw power when this signal is low
Power	I	Input internal pull down	12	Used to set high or low power mode
PullToGND	I		10	Used during manufacturing, connect to GND
GND		Power supply	9	Ground
Vcc		Power supply	14	Supply voltage
Vreg	O	Regulated 3V out	11	Power for D- pullup resistor
NC	-		13	do not connect

4.1 Pin Descriptions SpinWarrior 24R4

Name	I/O	Type	Pins	Description
D+, D-	I/O	special	16, 15	USB differential data lines
A0, B0	I	Input, internal pullup	1, 2	Quadrature signals for X axis encoder
A1, B1	I	Input, internal pullup	3, 4	Quadrature signals for Y axis encoder
A2, B2	I	Input, internal pullup	24, 23	Quadrature signals for Z axis encoder
A3, B3	I	Input, internal pullup	22, 21	Quadrature signals for Rx axis encoder
Sw0, Sw1, Sw2, Sw3, Sw4, Sw5, Sw6	I	Input, internal pullup	5, 20, 6, 19, 7, 18, 8	Switch inputs, contacts must close to ground
/En	O	OpenDrain, internal pullup	22, 21	Enable signal for encoders. Encoders can draw power when this signal is low
Power	I	Input internal pull down	12	Used to set high or low power mode
PullToGND	I		10	Used during manufacturing, connect to GND
GND		Power supply	9	Ground
Vcc		Power supply	14	Supply voltage
Vreg	O	Regulated 3V out	11	Power for D- pullup resistor
NC	-		13	do not connect

SpinWarrior

4.2 Pin Descriptions SpinWarrior 24R6

Name	I/O	Type	Pins	Description
D+, D-	I/O	special	16, 15	USB differential data lines
A0, B0	I	Input, internal pullup	1, 2	Quadrature signals for X axis encoder
A1, B1	I	Input, internal pullup	3, 4	Quadrature signals for Y axis encoder
A2, B2	I	Input, internal pullup	24, 23	Quadrature signals for Z axis encoder
A3, B3	I	Input, internal pullup	22, 21	Quadrature signals for Rx axis encoder
A4, B4	I	Input, internal pullup	19, 7	Quadrature signals for Ry axis encoder
A5, B5	I	Input, internal pullup	18, 8	Quadrature signals for Rz axis encoder
Sw0, Sw1, Sw2	I	Input, internal pullup	5, 20, 6	Switch inputs, contacts must close to ground
/En	O	OpenDrain, internal pullup	22, 21	Enable signal for encoders. Encoders can draw power when this signal is low
Power	I	Input internal pull down	12	Used to set high or low power mode
PullToGND	I		10	Used during manufacturing, connect to GND
GND		Power supply	9	Ground
Vcc		Power supply	14	Supply voltage
Vreg	O	Regulated 3V out	11	Power for D- pullup resistor
NC	-		13	do not connect

SpinWarrior

4.2 Pin descriptions

D+, D-

Differential data lines of USB. Connect these signals direct to a USB cable. D- requires a pull up resistor, see application circuit for details.

For a PCB layout make sure to run these two signals next to each other. USB data is a differential signal that produces best signal quality and lowest RF emission if the two lines are close to each other.

A0, B0

Quadrature inputs for the first axis. An encoder that generates two digital signals with $\pm 90^\circ$ offset must be connected to these inputs.

If channel A leads channel B by 90° the pulses reported by SpinWarrior will be positive.

The first encoder is reported as X axis.

CMOS level inputs with internal pullup resistor.

A1, B1

Quadrature inputs for the second axis.

The second encoder is reported as Y axis.

CMOS level inputs with internal pullup resistor.

Leave open if axis is not used.

A2, B2

Quadrature inputs for the third axis.

The third encoder is reported as Z axis.

CMOS level inputs with internal pullup resistor.

Leave open if axis is not used.

A3, B3 (SW24R4 and SW24R6 only)

Quadrature inputs for the fourth axis.

The fourth encoder is reported as Rx axis (rotational X).

CMOS level inputs with internal pullup resistor.

Leave open if axis is not used.

A4, B4 (SW24R6 only)

Quadrature inputs for the fifth axis.

The fifth encoder is reported as Ry axis (rotational Y).

CMOS level inputs with internal pullup resistor.

Leave open if axis is not used.

A5, B5 (SW24R6 only)

Quadrature inputs for the sixth axis.

The sixth encoder is reported as Rz axis (rotational Z).

CMOS level inputs with internal pullup resistor.

Leave open if axis is not used.

N0, N1, N3 (SW24A3)

Inputs for the index signals from the three encoders. A low to high edge on the Nx input resets the internal counter for that channel to zero.

CMOS level inputs with internal pull up resistor.

Leave open if not used.

Sw0..Sw6 (SW24R4)

Sw0..Sw2 (SW24R6)

Inputs for switches closing to ground.

Pulling a switch input low does signal an active switch. The switches are reported as HID buttons.

CMOS level inputs with internal pull up resistor.

In0..In5 (SW24A3)

Digital inputs active low.

Pulling one of these inputs low does signal an active status being reported via USB. The signals are not internally debounced, so care must be taken when switches are connected to these inputs.

CMOS level inputs with internal pull up resistor.

Leave open if not used.

Pull to GND

This pin is used during production of the SpinWarrior chips, connect to GND.

GND

Power supply ground.

Vcc

Supply voltage.

A 100nF ceramic capacitor is required to be connected directly to the power supply pins.

Vreg

Regulated 3V output, to be used only for the purpose of powering the USB D- pull up resistor.

Do not use this pin as a supply for any other circuit than the pull up resistor.

Power

Input to set the power mode. The status of the pin is checked only at power up and bus reset. Pulling this pin to high sets high power mode, this means the SpinWarrior 24 will report as a high power, bus powered device drawing up to 500mA. Pulling Power low on reset sets the low power mode specifying 100mA maximum power draw.

When using electromechanical encoders the Power pin can be tied low since the current will definitely stay below 100mA. For optical encoders the data sheet of the parts used should be checked for the current draw of these parts and the Power pin set accordingly. Keep in mind that the SpinWarrior

SpinWarrior

requires operating current too.

/En

To meet the USB suspend mode current limit it is necessary, that the encoders draw no current while the USB is suspended.

The /En pin is low when current may be drawn. When using mechanical encoders their common connector may be connected direct to the /En pin. For optical encoders check their data sheets to determine if the /En pin can sink sufficient current or if a driver is necessary. In any case a low side driver is recommended. Otherwise the SpinWarrior inputs may be pulled low through the encoders internal protection diodes which results in a unwanted current draw during suspend state.

SpinWarrior

5. Device Operation

Due to the fact that all current operating systems offer an especially easy access to devices in the HID class, SpinWarrior was designed as a generic HID device.

By identifying as a generic HID class device SpinWarrior avoids being controlled by any of the higher level system drivers, which makes it possible to access SpinWarrior from application level.

5.1 Accessing SpinWarrior

A common misconception with people new to the USB is that they think they can "talk to the USB port". The truth is that you do that as likely as you are going to directly talk to your Ethernet port or PCI bus.

Communication on the USB is always with a specific device attached to the USB. The USB itself is only the medium through which you communicate.

To get access to a certain device you have to look for the VendorID and ProductID of that device. The specific mechanism for doing so depends on the individual operating system.

For details refer to our sample code.

5.2 Movement direction

If channel A leads channel B by 90° the pulses reported by SpinWarrior will be positive.

5.3 Tracking accuracy

When using encoders with a clean signal that has no ringing or bouncing SpinWarrior will report the exact number of pulses it receives as long as the maximum edge rate for the encoder signal is not exceeded.

Exceeding the maximum edge rate can result in lost impulses.

Accessing the control endpoint 0 of SpinWarrior can also result in lost impulses even below the maximum edge rate. Access to the control endpoint happens only during enumeration of a USB device or when an application reads descriptors from the USB device. Both are not relevant during normal operation. The use of USB probing software is not recommended during normal operation.

Since SpinWarrior is using quadrant tracking it will report an impulse for each falling or rising edge on either signal A or B. This results in a resolution four times higher than that achieved by using A as the clock and B as the direction signal.

Reversing the movement direction can result in some pulses not getting reported. If the last pulses have not been transmitted before the direction changes subsequent pulses will be subtracted from the stored pulses.

This means the pulses seen by the computer for a given movement in one direction and then back will be the exact same, though it can happen that the maximum position does not get reported due to the direction reversal.

5.4 Using mechanical encoders

The use of electro mechanical encoders (i.e. encoders that use switches to generate the quadrature signals) should be limited to human input applications. It is not recommended to use electromechanical encoders or switches with SW24A3 at all.

Switches bounce, that means a contact closure is not immediate and final, the contact will close and open several times for a few milliseconds before becoming stable.

Usually this is compensated by a debounce logic either in hardware or software. But adding such a debounce logic would restrict the rotation speed that can be tracked to a level that feels uncomfortable.

SpinWarrior does not implement such a debounce logic for the encoders to allow maximum tracking speed. Though this also means some additional spurious pulses may be detected.

Due to the quadrant tracking used by SpinWarrior such false pulses usually are compensated. Though testing shows that some pulses may actually be added by mechanical encoders. This makes them unsuitable for exact tracking like in motion control.

5.5 Power supply

USB does allow a device to be "Bus Powered". This means the device does get its power off the USB port. To avoid overloading on the USB ports devices need to advertise their power requirements. There are two power classes for devices: Low power and high power. Low power devices may draw up to 100mA off the USB, high power devices up to 500mA.

Likewise there are high power and low power ports. Usually high power ports are those on the motherboard and on hubs with external power supply or hubs in a monitor. Low power ports are typically on hubs that get their power off the USB, like hubs in keyboards.

If the system decides that there is not sufficient

SpinWarrior

power to supply a high power device that device does not get enabled.

SpinWarrior can operate either as a high power or low power device. Pulling the Power pin high or low at reset sets the desired power rating.

This allows to configure SpinWarrior optimally for supporting the encoders used.

5.6 Suspend

All devices on USB need to support the suspended state. When the host computer stops to periodically access the USB, like when it goes to sleep, all devices need to enter the suspended state and drop their power draw to less than $500\mu\text{A}$ for low power devices or less than 2.5mA for high power devices.

When entering suspended state SpinWarrior pulls the /En pin high. Care must be taken in designing the external circuit so that it will draw no more than the allowed suspend power rating while /En is high.

5.7 Remote Wakeup

SpinWarrior chips support the remote wakeup feature. They are able to wake the host computer from sleep state if the host operating system has enabled this feature.

Remote wakeup is initiated by SpinWarrior if any of the switch inputs is pulled low while the chip is in suspended state.

5.8 Data Report Format

SpinWarrior24A3 keeps a 16 bit count for each encoder position and reports this as an absolute position. The count gets reset to zero on a low to high going edge of the N input of that encoder channel. For performance reasons SW24A3 does continuously send data instead of just sending data when a change occurred.

SpinWarrior24R4 and SpinWarrior24R6 keep an 8 bit count of encoder impulses received since the last data transmission. To measure an absolute position with them it is necessary to sum up all received data packets on the controlling computer. SW24Rx sends data only if there is a change in the count or the status of a button.

SpinWarrior24A3 sends reports with 7 byte length:

Byte0 - X LSB
 Byte1 - X MSB
 Byte2 - Y LSB
 Byte3 - Y MSB
 Byte4 - Z LSB
 Byte5 - Z MSB
 Byte6 - Switches

SpinWarrior24R4 sends reports with 5 byte length:

Byte0 - X
 Byte1 - Y
 Byte2 - Z
 Byte3 - rX
 Byte4 - Switches

SpinWarrior24R6 sends reports with 6 byte length:

Byte0 - X
 Byte1 - Y
 Byte2 - Z
 Byte3 - rX
 Byte4 - rY
 Byte5 - rZ
 Byte6 - Switches

SpinWarrior

6. Absolute Maximum Ratings

Storage Temperature	-65°C to +150°C
Ambient Temperature with power applied.....	-0°C to +70°C
Supply voltage on Vcc relative to Gnd	-0.5V to +7V
DC input voltage.....	-0.5V to Vcc+0.5V
Maximum current into all ports.....	70mA
Power Dissipation.....	300mW
Static discharge voltage.....	>2000V
Latch-up current.....	>200mA

6.1 DC Characteristics

	Parameter	Min	Max	Units	Remarks
V _{cc}	Operating Voltage	4.35	5.25	V	
I _{cc}	Operating Supply Current		20	mA	
I _{sb}	Suspend mode current		25	μA	Oscillator off
I _{ol}	Max sink current on output pins		70	mA	Cummulative across all ports
I _{ol}	Sink current on /En		25	mA	Vout =0.4V
R _{up}	Pull-up Resistance	8	24	kΩ	
V _{icr}	Input threshold voltage	40%	60%	V _{cc}	All inputs, low to high edge
V _{icf}	Input threshold voltage	40%	60%	V _{cc}	All inputs, high to low edge
V _H	Input hysteresis voltage	3%	10%	V _{cc}	
	USB Interface				
V _{oh}	Static output high	2.8	3.6	V	15kΩ±5% to GND
V _{ol}	Static output low		0.3	V	
V _{di}	Differential Input sensitivity	0.2		V	$(D+) - (D-)$
V _{cm}	Differential Input common Mode Range	0.8	2.5	V	
V _{se}	Single Ended Transceiver Threshold	0.8	2.0	V	
C _{in}	Transceiver capacitance		20	pF	
I _{io}	Hi-Z State Data Line Leakage	-10	10	μA	0V < Vin < 3.3V, Hi-Z State
R _{pu}	Bus Pull-up resistance	1.274	15.75	kΩ	1.3kΩ±2% to Vreg
R _{pd}	Bus Pull-down resistance	14.25	15.75	kΩ	15kΩ±5%

SpinWarrior

6.2 AC Characteristics

	Parameter	Min	Max	Units	Remarks
USB Driver Characteristics					
t_r	Transition rise time	75		ns	C _{Load} = 50pF
t_r	Transition rise time		300	ns	C _{Load} = 350pF
t_f	Transition fall time	75		ns	C _{Load} = 50pF
t_f	Transition fall time		300	ns	C _{Load} = 350pF
t_{rfm}	Rise/Fall Time matching	80	120	%	
V_{crs}	Output signal crossover voltage	1.3	2.0	V	
USB Data Timing					
t_{drate}	Low Speed Data Rate	1.4777	1.5225	MBit/s	
t_{djr1}	Receiver data jitter tolerance	-75	75	ns	To next transition
t_{djr2}	Receiver data jitter tolerance	-45	45	ns	For paired transitions
t_{deop}	Differential to EOP transition skew	-40	100	ns	
t_{eopr1}	EOP width at receiver	165		ns	Rejects as EOP
t_{eopr2}	EOP width at receiver	675		ns	Accepts as EOP
t_{eopt}	Source EOP width	1.25	1.50	μ s	
t_{udj1}	Differential driver jitter	-95	95	ns	To next transition
t_{udj2}	Differential driver jitter	-150	150	ns	To paired transition

6.3 Encoder Timing

Minimum timing for the encoders is specified as the time from edge to edge on any of the two signals for each encoder. The time from any edge on signal A to an edge on signal B, or vice versa, or any two edges on either signal A or B must not be shorter than what is specified as t_{min} .

6.3.1 Encoder Timing SW24A3

All three encoders operating: $t_{min} = 64.1\mu$ s, $f_{max} = 3900$ Hz

Only X and Y operating: $t_{min} = 56.8\mu$ s, $f_{max} = 4400$ Hz

Only X operating: $t_{min} = 50\mu$ s, $f_{max} = 5000$ Hz

Non operating encoder inputs must be left unconnected to assure the specified timing

6.3.2 Encoder Timing SW24R4

All encoders operating: $t_{min} = 71\mu$ s, $f_{max} = 3500$ Hz

6.3.3 Encoder Timing SW24R6

All encoders operating: $t_{min} = 100\mu$ s, $f_{max} = 2500$ Hz

SpinWarrior

7. Ordering information

Partname	Order Code	Description	Package
SpinWarrior24A3	SW24A3-P	Rotary encoder controller for 3 encoders, absolute	PDIP24
SpinWarrior24A3	SW24A3-S	Rotary encoder controller for 3 encoders, absolute	SOIC24
SpinWarrior24R4	SW24R4-P	Rotary encoder controller for 4 encoders, relative	PDIP24
SpinWarrior24R4	SW24R4-S	Rotary encoder controller for 4 encoders, relative	SOIC24
SpinWarrior24R6	SW24R6-P	Rotary encoder controller for 6 encoders, relative	PDIP24
SpinWarrior24R6	SW24R6-S	Rotary encoder controller for 6 encoders, relative	SOIC24

The chips listed here are standard products. Customized chips are available on request.

7.1 Packaging info

PDIP24 chips come in tubes of 16 each.
SOIC24 chips come in tubes of 31 each.
To assure best handling and shipping safety please order the chips in full tubes if possible.

7.2 USB VendorID and ProductID

By default all SpinWarrior chips are shipped with the USB VendorID of Code Mercenaries (\$7C0 or decimal 1984) and a fixed ProductID.

On request chips can be equipped with the customers VendorID and ProductID. VendorIDs can be obtained from the USB Implementers Forum <www.usb.org>

Customized chips may be subject to minimum order quantities, contact <sales@codemerchs.com> for details.

Following are the ProductIDs for the SpinWarrior controllers:

SpinWarrior24R4	\$1200
SpinWarrior24R6	\$1201
SpinWarrior24A3	\$1202

ProductIDs are independent of the package type.

7.3 Serial numbers

SpinWarrior chips do have unique serial numbers in their device descriptors. These serial numbers can be used to simplify programming for multiple SpinWarriors connected to a single computer.

The serial numbers are factory programmed and can not be changed. Serial numbers are 8 digit hexadecimal numbers. No two chips of a type will be produced with identical serial numbers. Though it can be that a SW24R4 has the same serial number as a SW24R6 or SW24A3 chip.

It is not possible to order chips with a specific serial number unless they are ordered as custom chips which are subject to minimum order volumes and setup charges.

SpinWarrior

8.2 SpinWarrior24R6 with optical encoders

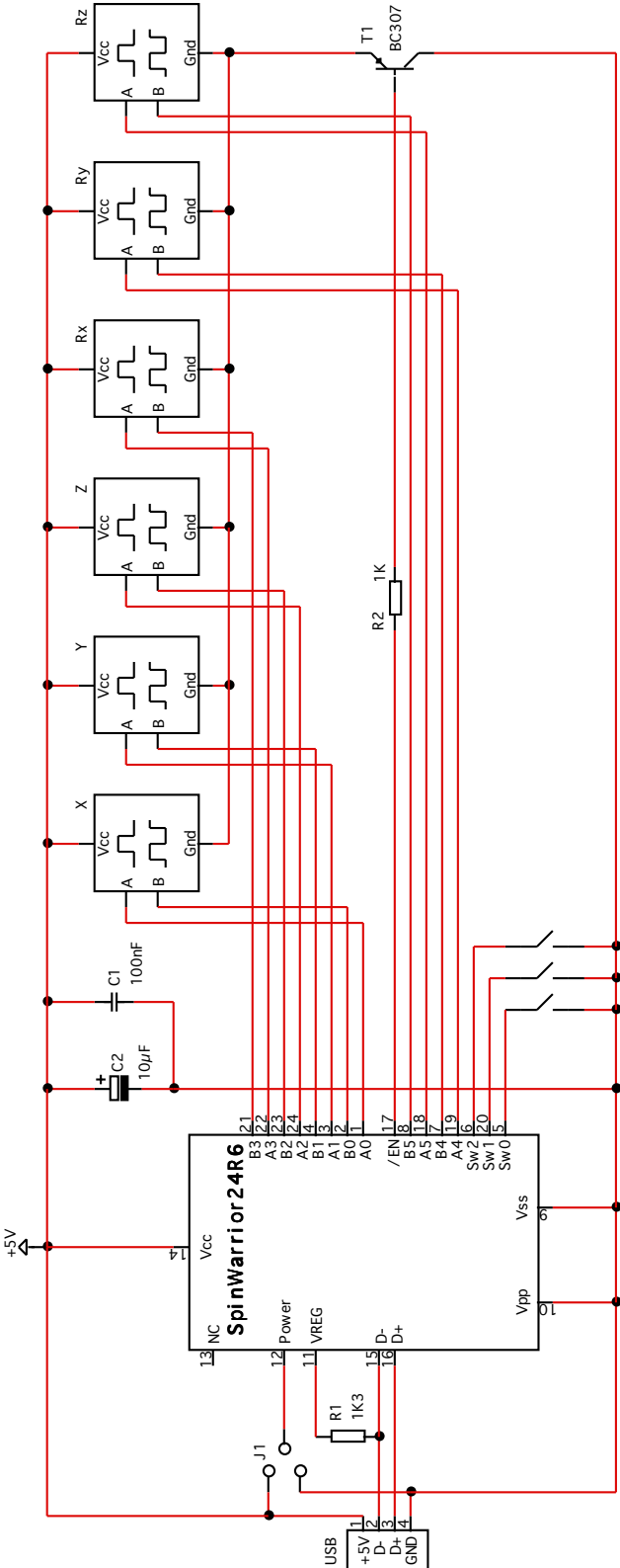

J1 pulling high sets high power mode (500mA)
 J1 pulling low sets low power mode (100mA)

R2/T1: Check the data sheet of your encoders to assure this circuit is sufficient

The low side driver circuit for the power supply of the encoders is just an example. Actual driver circuits should be designed to fit the requirements of the encoders used.

Circuit: SpinWarrior24R6				
Version: 1.0				
Date: 8.11.2005				
Drawn by:				
Function:				
Pane:				
Rev.	Date	By	Change	Sign.

SpinWarrior

8.3 SpinWarrior 24R6 with mechanical encoders

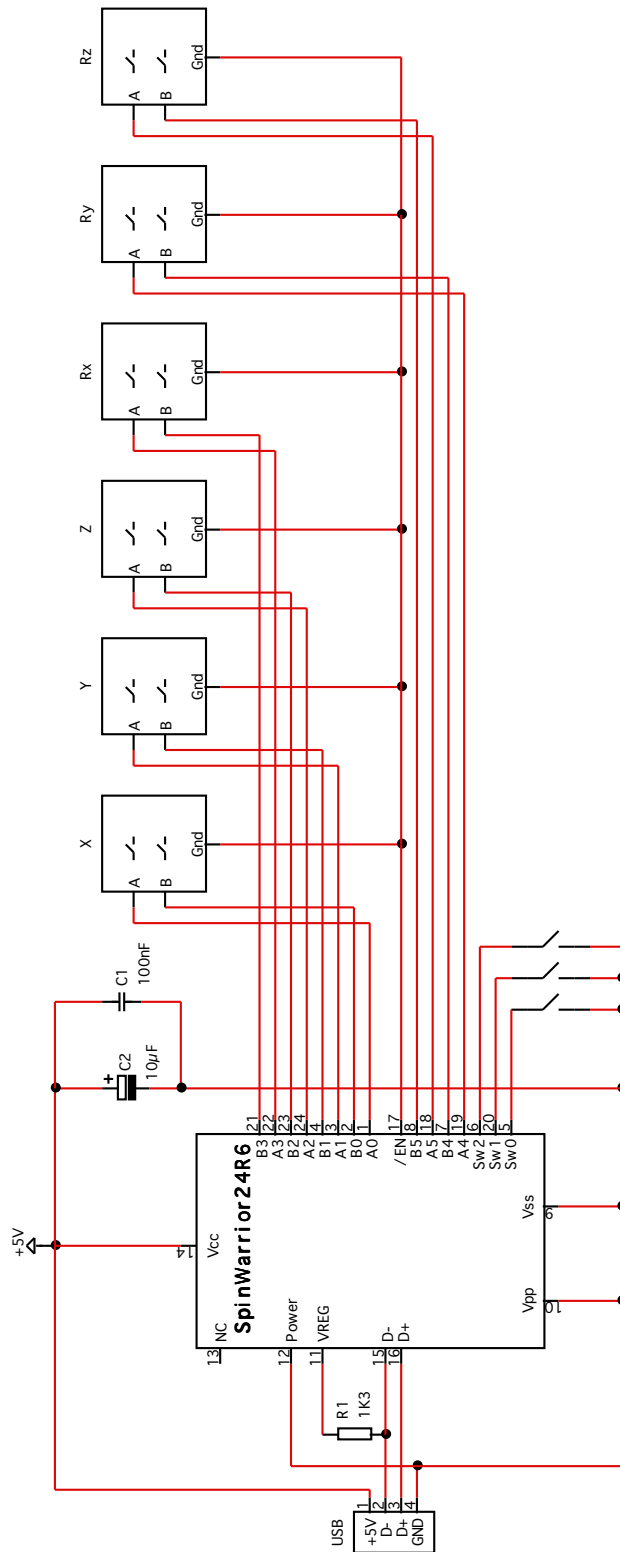

 Code Mercenaries				
Circuit: SpinWarrior24R6				
Version: 1.0				
Date: 8.11.2005				
Drawn by:				
Function:				
Page:				
Rev.	Date	By	Change	Sign.

The common connectors of the mechanical encoders should be connected to /En and not to ground. This ensures that the encoders do not drain current through the internal pull up resistors of the SpinWarrior while in suspend mode.

SpinWarrior

8.3 SpinWarrior 24A3

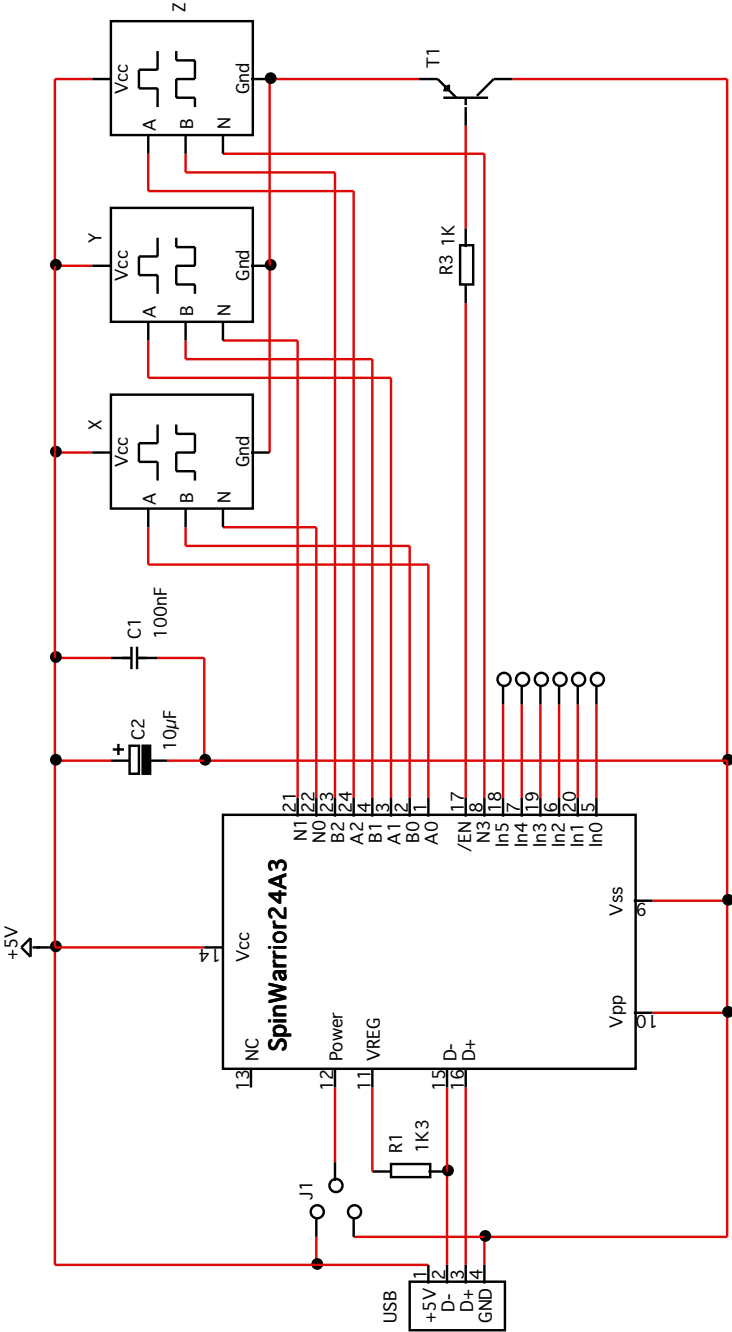

J1 pulling high sets high power mode (500mA)
J1 pulling low sets low power mode (100mA)

Code Mercenaries				
Circuit:	SpinWarrior 24A3			
Version:	1.0			
Date:	28.2.2007			
Drawn by:				
Function:				
Page:				
Rev.	Date	By	Change	Sign.

SpinWarrior

9. Package Dimensions

24 Pin DIL

DIMENSIONS IN INCHES MIN. MAX.

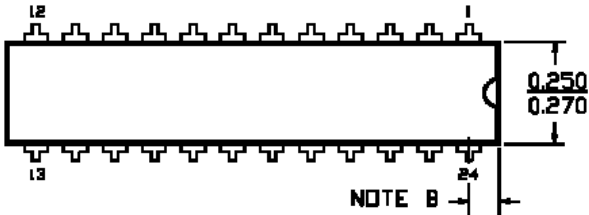

	P 13	P 13A
NOTE A	1.170 1.200	1.230 1.260
NOTE B	0.030 0.050	0.060 0.080

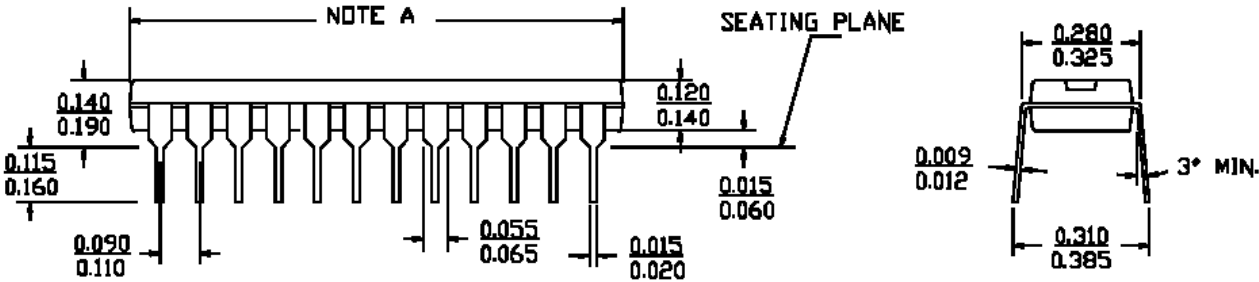

24 Pin SOIC

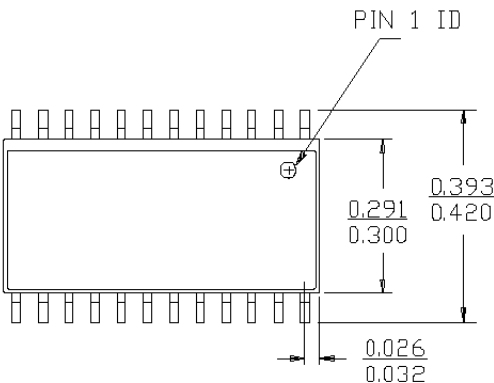

DIMENSIONS IN INCHES MIN. MAX.
LEAD COPLANARITY 0.004 MAX.

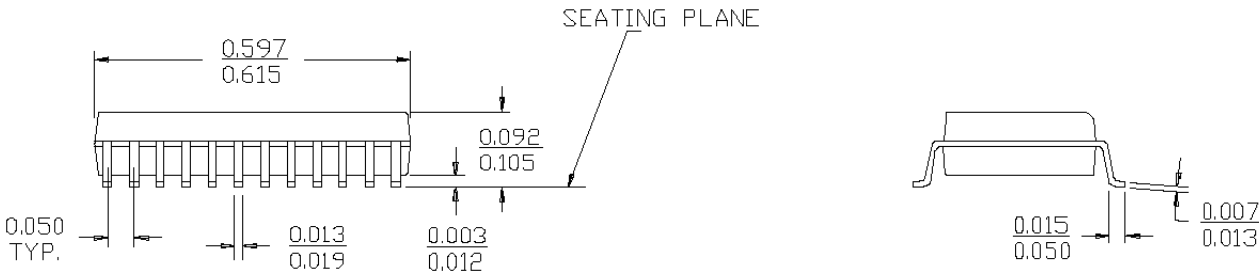

SpinWarrior

10. ESD Considerations

SpinWarrior has an internal ESD protection to withstand discharges of more than 2000V without permanent damage. However ESD may disrupt normal operation of the chip and cause it to exhibit erratic behaviour.

For the typical office environment the 2000V protection is normally sufficient. Though for industrial use additional measures may be necessary.

When adding ESD protection to the signals special care must be taken on the USB signal lines. The USB has very low tolerance for additional resistance or capacitance introduced on the USB differential signals.

Series resistors of 27Ω may be used alone or in addition to some kind of suppressor device. In any case the USB 2.0 specification chapter 6 and 7 should be read for detailed specification of the electrical properties.

10.1 EMC Considerations

SpinWarrior uses relatively low power levels and so it causes few EMC problems. The most important issue is to provide a very clean layout for the power supply. SpinWarrior runs at 12MHz internal clock rate, this can cause current spikes if the supply lines are not carefully laid out.

To avoid any EMC problems the following rules should be followed:

- Keep the PCB traces from the resonator to the chip pins as short as possible.
- Put the 100nF ceramic capacitor right next to the power supply pins of the chip and make sure the PCB traces between the chips power pins and the capacitor are as short as possible.
- Run the power supply lines first to the capacitor, then to the chip.
- Keep the two USB signal lines close to each other, route no other signal between them. USB uses differential signalling so the best signal quality with lowest RF emission is achieved by putting these lines very close to each other.

11. Revision History

1.1.0.0

- Added SW24A3.
- Improved tracking performance.
- Fixed a problem that could cause single data packets to be lost on SW24R4 and SW24R6.

1.0.0.0

- This is the initial release version of SpinWarrior.

SpinWarrior

Legal Stuff

This document is ©1999-2014 by Code Mercenaries.

The information contained herein is subject to change without notice. Code Mercenaries makes no claims as to the completeness or correctness of the information contained in this document.

Code Mercenaries assumes no responsibility for the use of any circuitry other than circuitry embodied in a Code Mercenaries product. Nor does it convey or imply any license under patent or other rights.

Code Mercenaries products may not be used in any medical apparatus or other technical products that are critical for the functioning of lifesaving or supporting systems. We define these systems as such that in the case of failure may lead to the death or injury of a person. Incorporation in such a system requires the explicit written permission of the president of Code Mercenaries.

Trademarks used in this document are properties of their respective owners.

Code Mercenaries
Hard- und Software GmbH
Karl-Marx-Str. 147a
12529 Schönefeld OT Grossziethen
Germany
Tel: x49-3379-20509-20
Fax: x49-3379-20509-30
Mail: support@codemerics.com
Web: www.codemerics.com

HRB 9868 CB
Geschäftsführer: Guido Körber, Christian Lucht