

# MW24H8

**Hybrid mouse and joystick controller  
For various sensor technologies  
Supplement to the JoyWarrior data sheet**

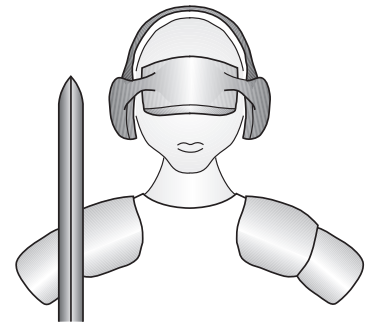

**Code Mercenaries**

## 1. Features

- USB low speed interface
- Full USB V1.1/2.0 compliance
- Full USB HID 1.1 compliance
- Analog input for three axis joystick or mouse with scroll function
- Compatible with many sensor technologies, including Hall sensors and potentiometers
- Up to 6 buttons supported
- On-the-fly switching between joystick and mouse operation
- Autocalibration and auto-centering
- Dynamic recentering for drift compensation
- Low cost external A/D converter for optimal sensor adaption
- Single +5V power supply
- Available in 24 pin DIL, or 24 pin SOIC

### 1.1 Variants

MouseWarrior24H8 is available in one variant only.

### 1.2 Custom variants

Custom adaptations are available on request. Production of chips with different product names is available for volumes of 100 or more.

## 2. Functional overview

MouseWarrior24H8 does use analog input either for cursor control as a six button mouse with scroll wheel or as a three axis joystick. Switching between joystick and mouse mode can be done at any time by pulling the /Joy mode pin low or high. By utilizing an inexpensive external A/D converter MW24H8 allows the use of a wide range of sensor technologies for cursor controls. Hall effect or potentiometer joysticks may be used, or any other sensor technology that produces a 0..5V voltage output. With additional analog signal conditioning it is possible to use any kind of sensor.

By utilizing the USB standard joystick protocol MW24H8 can be easily used via the game controller input functions on any operating system. At the same time the mouse function can be used via the standard mouse driver of the system.

# MW24H8

## 3. Pin Configurations

MouseWarrior24H8-P/S  
24 Pin PDIP or 24 Pin SOIC

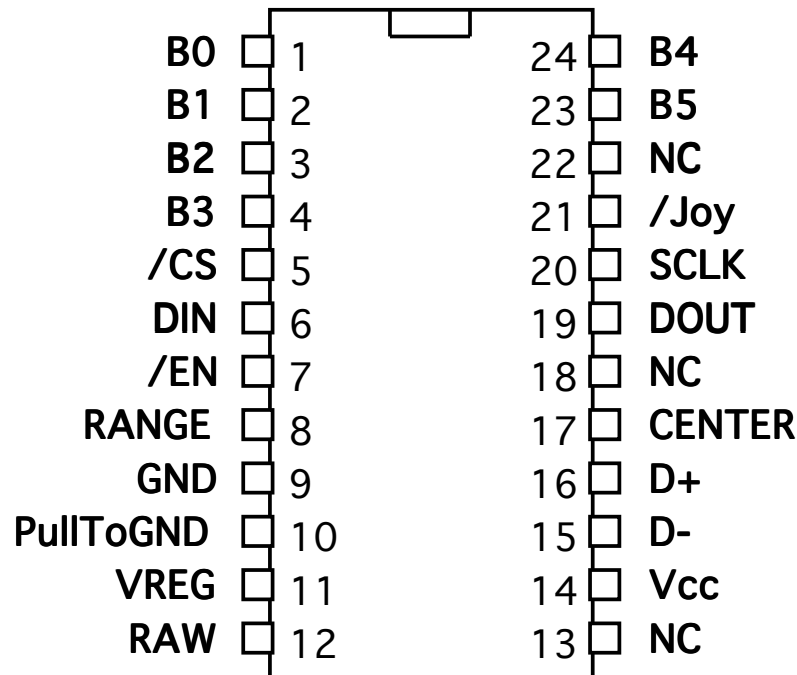

Drawing: TOP VIEW!

## 4. Pin Descriptions MouseWarrior24H8

Name	I/O	Type	Pins	Description
D+, D-	I/O	special	16,15	USB differential data lines
B0, B1, B2, B3, B4, B5	I	input, internal pull up	1, 2, 3, 4, 24, 23	Button inputs, active low
/Joy	I	input, internal pull up	21	Mode pin, pull low to switch to joystick function
/CS, SCLK, DOUT	O	open drain, internal pull up	5, 20, 19	Connect to MAX1113
DIN	I	input, internal pull up	6	Connect to MAX1113
RANGE	I	input, internal pull up	8	Pull down to reduce input value range used for mouse movement, i.e. higher sensitivity
CENTER	I	input, internal pull up	17	Pull down to disable automatic recentering
/EN	O	open drain, internal pull up	7	Enable output to switch power for sensors
VREG	O	special *	11	Power for USB D- pull up resistor
PullToGND	I		10	Used during manufacturing, connect to GND
GND		Power supply	9	Ground
Vcc		Power supply	14	Supply voltage
NC			13, 18, 22	do not connect
RAW	I	input, internal pull down	12	Pull to Vcc to disable auto calibration and centering

\*) See application circuit for details

# MW24H8

## 4.1 Pin descriptions

### D+, D-

Differential data lines of USB. Connect these signals direct to a USB cable. D- requires a 1K3 resistor connecting to VREG, see application circuits for details.

### B0..B5

Inputs for the buttons. Connect contacts closing to ground.

Internal pull up resistors.

### VREG

Supplies 3.3V for the USB D- pull up resistor. Don't use this pin to supply power to external circuitry, it does only supply sufficient current for the pull up resistor.

### /CS, SCLK, DOUT, DIN

Connect these pins to the corresponding pins of a MAX1113 A/D converter.

### /RANGE

Pulling this pin low doubles the sensitivity of the mouse function. i.e. half of the value range of the input signal will be sufficient to get to full cursor speed. This option can be used to compensate reduced voltage swing from the sensor or a circular movement restriction of the sensor (like on a FID820). This does not affect the joystick data.

Internal pull up resistor.

### /CENTER

Pulling this pin low disables the automatic recentering. Automatic recentering does adjust the center, or non moving position if the input value is stable on a non center value for a longer time period.

This function compensates drift in the sensor.

Internal pull up resistor.

### RAW

Pulling this pin to Vcc disables the autocalibration and auto-centering function. The chip will then report the raw axis data. This can be useful during design test or for applications that can't accept the autocalibration or auto-centering feature.

Internal weak pull down resistor.

### /EN

Enable output to control the power for the sensors. To comply with the suspend mode maximum current consumption on the USB it may be necessary to switch off the power to the sensors.

This pin goes low when power to the sensor should be on. Use whatever circuitry necessary to control the supply power for your sensors.

Open drain output with internal pull up resistor.

### /Joy

Pulling this pin low disables the mouse function and enables the joystick function. All axis data is then reported in joystick format. Letting the pin float high does enable the mouse mode in which the X/Y axis position is translated into cursor movements when the axis position is not center.

Internal pull up resistor.

### GND

Power supply ground.

### Vcc

Supply voltage.

# MW24H8

## 5. Device Operation

By following the USB HID specifications MouseWarrior chips are able to work with most operating systems without the need to supply special drivers. Any operating system with support for USB HID mice and game controllers will have the necessary drivers already in place.

### 5.1 Operation with Windows

Any Windows versions 98 and newer and 2000 and newer will work with MouseWarrior. Older versions of Windows do not support USB.

Upon connecting a MouseWarrior based device for the first time you may be asked to perform the standard driver install. The same happens if you connect the device to a different USB port on the same computer.

After the driver installation has completed you should be able to see the device in the "Game Controllers" control panel and be able to access it via DirectInput. Also a mouse should show up in the device manager and when in mouse mode the MW24H8 should be able to control the mouse cursor.

### 5.2 Operation with MacOS

MacOS 9.0 and up and MacOS X do support MouseWarrior direct. Some versions of MacOS 8.x do support USB as well, though their use is not recommended.

With MacOS 9.x you will be able to use MouseWarrior based devices via InputSprocket or with 3rd party software like USB Overdrive.

On MacOS X access is available via the HIDManager.

There will be no warnings or dialogs when a properly functioning MouseWarrior based device is connected under MacOS, it will simply start to work.

### 5.3 Power via USB

MouseWarrior24H8 requests 100mA total power off the USB. Make sure the complete circuit including the sensors stays within this current budget.

### 5.4 Suspend Mode

MouseWarrior24H8 does support the USB suspend mode. When detecting no bus activity MouseWarrior24H8 will put the external A/D converter to sleep mode and disable the /EN pin to switch off power to the sensors. Then it enters sleep mode itself.

If the sensors use more than  $400\mu\text{A}$  the power to them must be controlled using the /EN output to make sure the device stays within the  $500\mu\text{A}$  current limit for USB suspend mode.

### 5.5 Remote Wakeup

MouseWarrior24H8 does support Remote Wakeup of a sleeping host. The wake up can take place when a button is pressed while the host is sleeping. Remote wakeup has to be enabled by the operating system.

# MW24H8

## 6. Absolute Maximum Ratings

Storage Temperature .....	-65°C to +150°C
Ambient Temperature with power applied .....	0°C to +70°C
Supply voltage on Vcc relative to Gnd .....	-0.5V to +7V
DC input voltage.....	-0.5V to Vcc+0.5V
Maximum current into all ports.....	70mA
Power Dissipation.....	300mW
Static discharge voltage.....	>2000V
Latch-up current.....	>200mA

### 6.1 DC Characteristics

	Parameter	Min	Max	Units	Remarks
V <sub>cc</sub>	Operating Voltage	4.35	5.25	V	
I <sub>cc</sub>	Operating Supply Current		20	mA	
I <sub>sb</sub>	Suspend mode current		25	μA	Oscillator off
I <sub>ol</sub>	Sink current on output pins		70	mA	V <sub>out</sub> = 0.4V
R <sub>up</sub>	Pull-up Resistance	8	24	kΩ	
V <sub>ith</sub>	Input Threshold Voltage	40%	60%	V <sub>cc</sub>	
	<b>USB Interface</b>				
V <sub>oh</sub>	Static output high	2.8	3.6	V	15kΩ±5% to GND
V <sub>ol</sub>	Static output low		0.3	V	
V <sub>di</sub>	Differential Input sensitivity	0.2		V	$(D+) - (D-)$
V <sub>cm</sub>	Differential Input common Mode Range	0.8	2.5	V	
V <sub>se</sub>	Single Ended Transceiver Threshold	0.8	2.0	V	
C <sub>in</sub>	Transceiver capacitance		20	pF	
I <sub>io</sub>	Hi-Z State Data Line Leakage	-10	10	μA	0V < V <sub>in</sub> < 3.3V, Hi-Z State
R <sub>pu</sub>	Bus Pull-up resistance	1.274	1.326	kΩ	1.3kΩ±2% to V <sub>reg</sub>
R <sub>pd</sub>	Bus Pull-down resistance	14.25	15.75	kΩ	15kΩ±5%

# MW24H8

## 6.2 AC Characteristics

	Parameter	Min	Max	Units	Remarks
F <sub>iclk2</sub>	Internal clock frequency	5.91	6.09	MHz	Clock synchronized to USB
<b>USB Driver Characteristics</b>					
t <sub>r</sub>	Transition rise time	75		ns	C <sub>Load</sub> = 50pF
t <sub>r</sub>	Transition rise time		300	ns	C <sub>Load</sub> = 350pF
t <sub>f</sub>	Transition fall time	75		ns	C <sub>Load</sub> = 50pF
t <sub>f</sub>	Transition fall time		300	ns	C <sub>Load</sub> = 350pF
t <sub>rfm</sub>	Rise/Fall Time matching	80	125	%	
V <sub>crs</sub>	Output signal crossover voltage	1.3	2.0	V	
<b>USB Data Timing</b>					
t <sub>drate</sub>	Low Speed Data Rate	1.4775	1.5225	MBit/s	
t <sub>djr1</sub>	Receiver data jitter tolerance	-75	75	ns	To next transition
t <sub>djr2</sub>	Receiver data jitter tolerance	-45	45	ns	For paired transitions
t <sub>deop</sub>	Differential to EOP transition skew	-40	100	ns	
t <sub>eoпр1</sub>	EOP width at receiver	165		ns	Rejects as EOP
t <sub>eoпр2</sub>	EOP width at receiver	675		ns	Accepts as EOP
t <sub>eoрt</sub>	Source EOP width	1.25	1.50	μs	
t <sub>udj1</sub>	Differential driver jitter	-95	95	ns	To next transition
t <sub>udj2</sub>	Differential driver jitter	-150	150	ns	To paired transition

# MW24H8

## 7. Ordering information

Partname	Order Code	Description	Package
MouseWarrior24 H8	MW24H8-P	Joystick / Mouse hybrid controller	PDIP24
MouseWarrior24 H8	MW24H8-S	Joystick / Mouse hybrid controller	SOIC24

The chips listed here are standard products. Customized chips are available on request.

### 7.1 Packaging info

PDIP24 chips come in tubes with 16 chips each. SOIC24 chips come in tubes with 31 chips each. To assure best handling and shipping safety please order the chips in full tubes. Custom chips are produced in multiples of full tubes only.

### 7.2 USB VendorID and ProductID

By default all MouseWarrior chips are shipped with the USB VendorID of Code Mercenaries (\$7C0 or decimal 1984) and a fixed ProductID.

On request chips can be equipped with the customers VendorID and ProductID. VendorIDs can be obtained from the USB Implementers Forum <[www.usb.org](http://www.usb.org)>

Customized chips are subject to minimum order quantities, contact <[sales@codemercs.com](mailto:sales@codemercs.com)> for details.

Following are the ProductIDs for the MouseWarrior controllers:

MouseWarrior24 H8                      \$1115

ProductIDs are independent of the package type.

See the JoyWarrior data sheet for version information.

# MW24H8

## 8. Typical application for MouseWarrior24 H8

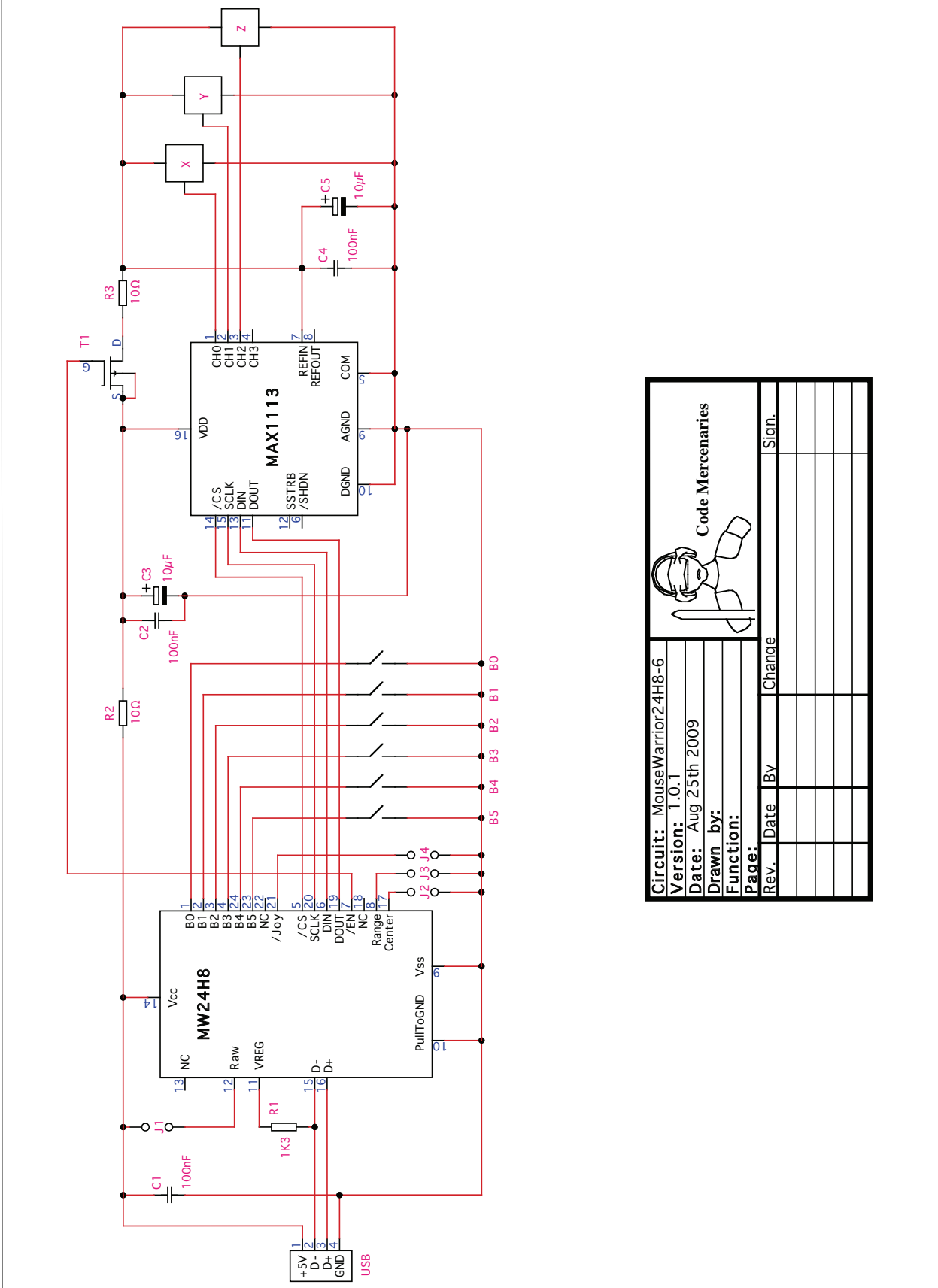

				
<b>Circuit:</b> MouseWarrior24H8-6				
<b>Version:</b> 1.0.1				
<b>Date:</b> Aug 25th 2009				
<b>Drawn by:</b>				
<b>Function:</b>				
<b>Page:</b>				
Rev.	Date	By	Change	Sign.

# MW24H8

## 9. Package Dimensions 24 Pin PDIP

DIMENSIONS IN INCHES MIN.  
MAX.

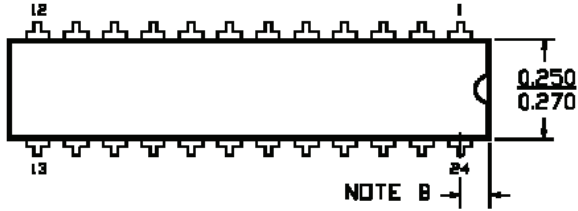

	P 13	P 13A
NOTE A	1.170 1.200	1.230 1.260
NOTE B	0.030 0.050	0.060 0.080

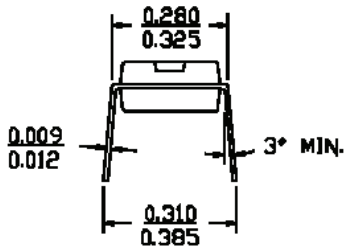
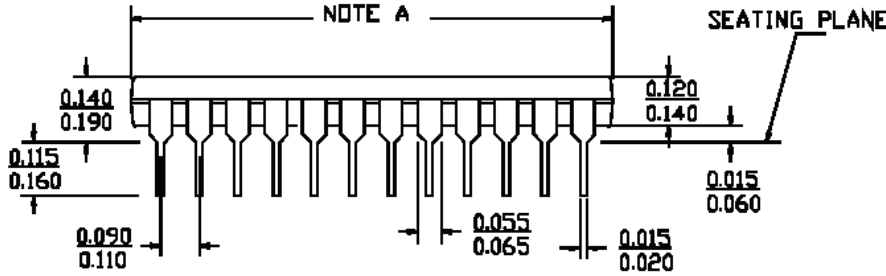

## 24 Pin SOIC

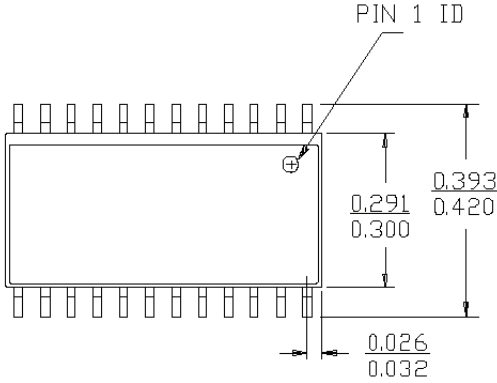

DIMENSIONS IN INCHES MIN.  
MAX.  
LEAD COPLANARITY 0.004 MAX.

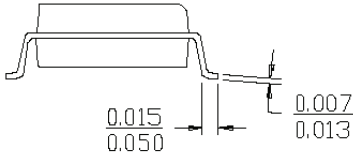
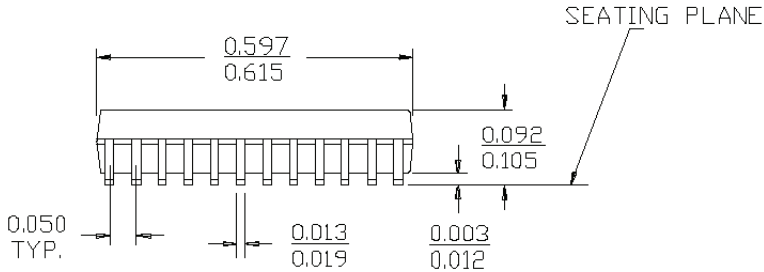

# MW24H8

## 10. ESD Considerations

MouseWarrior has an internal ESD protection to withstand discharges of more than 2000V without permanent damage. However ESD may disrupt normal operation of the chip and cause it to exhibit erratic behaviour.

For the typical office environment the 2000V protection is normally sufficient. Though for industrial use additional measures may be necessary.

When adding ESD protection to the signals special care must be taken on the USB signal lines. The USB has very low tolerance for additional resistance or capacitance introduced on the USB differential signals.

Series resistors of  $27\Omega$  may be used alone or in addition to some kind of suppressor device. In any case the USB 2.0 specification chapter 6 and 7 should be read for detailed specification of the electrical properties.

### 10.1 EMC Considerations

MouseWarrior uses relatively low power levels and so it causes few EMC problems.

To avoid any EMC problems the following rules should followed:

- Put the 100nF ceramic capacitor right next to the power supply pins of the chip and make sure the PCB traces between the chips power pins and the capacitor are as short as possible.
- Run the power supply lines first to the capacitor, then to the chip.
- Keep the two USB signal lines close to each other, route no other signal between them. USB uses differential signalling so the best signal quality with lowest RF emission is achieved by putting these lines very close to each other.
- Adding a ferrite bead to the +5V power supply line is advisable.

## 11. Revision History

Please refer to the JoyWarrior main data sheet for the revision history.

### 11.1 Data sheet revision history

V1.0.1 Fixed a mistake in the sample circuit, USB data lines were switched.

## Legal Stuff

This document is ©1999-2011 by Code Mercenaries.

The information contained herein is subject to change without notice. Code Mercenaries makes no claims as to the completeness or correctness of the information contained in this document.

Code Mercenaries assumes no responsibility for the use of any circuitry other than circuitry embodied in a Code Mercenaries product. Nor does it convey or imply any license under patent or other rights.

Code Mercenaries products may not be used in any medical apparatus or other technical products that are critical for the functioning of lifesaving or supporting systems. We define these systems as such that in the case of failure may lead to the death or injury of a person. Incorporation in such a system requires the explicit written permission of the president of Code Mercenaries.

Trademarks used in this document are properties of their respective owners.

Code Mercenaries  
 Hard- und Software GmbH  
 Karl-Marx-Str. 147a  
 12529 Schönefeld  
 Germany  
 Tel: x49-3379-20509-20  
 Fax: x49-3379-20509-30  
 Mail: support@codemerics.com  
 Web: www.codemerics.com

HRB 16007 P

Geschäftsführer: Guido Körber, Christian Lucht