

# MW24F8

## 3D acceleration sensor for mouse input

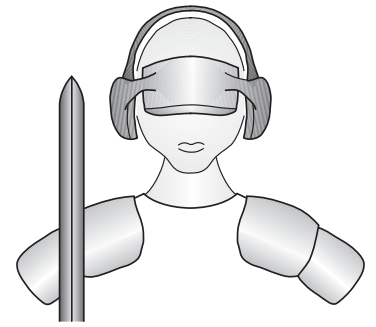

Code Mercenaries

### 1. Features

- USB interface (low speed)
- Full USB V1.1/2.0 compliance
- Full USB HID 1.1 compliance
- 3 axis acceleration sensor
- Mouse movement controlled by tilt angle or acceleration
- Scrolling by gesture detection (vertical movement)
- Jumper selectable range
- Button selectable scrolling option
- Up to 6 buttons supported
- Single +5V power supply
- Available as completely assembled ready to use module or as a USB interface chip in 24 pin SOIC package (not including the sensor element)

#### 1.1 Variants

MouseWarrior24F8 is available as either a completely assembled module including the MEMS sensor, or as just the USB interface chip in SOIC24 package. The interface chip does not include the sensor. The option to buy the interface chip separately is intended for volume production where a tighter integration with the target device is required.

#### 1.2 Custom variants

Custom adaptations are available on request. Customization may be subject to minimum order volumes.

### 2. Functional overview

MouseWarrior24F8 uses a MEMS solid state 3 axis acceleration sensor for acceleration or inclination sensing. The X and Y axes are converted into mouse movement data.

This allows to build a completely sealed mouse sensor as no external moving parts are required and no special electrical or mechanical properties need to be observed to allow proper sensor operation.

The Z axis may be used for scrolling, or the Y axis can be used for scrolling when a designated button is pressed.

#### 2.1 Scrolling

Vertical scrolling can be done by gesture detection. The Z axis is used in combination with X and Y to detect purely vertical movement.

If a purely vertical movement is detected this information is used to generate scroll data. The initial direction of the movement is used to detect the intended direction of scrolling.

It takes a little practice to properly use this function and it works best if the device in which MW24F8 is embedded is used while standing, rather than sitting in front of the computer screen.

# MW24F8

### 3.0 Pin configurations

**MouseWarrior24F8-S**  
**24 Pin SOIC**  
**Drawing: TOP VIEW!**

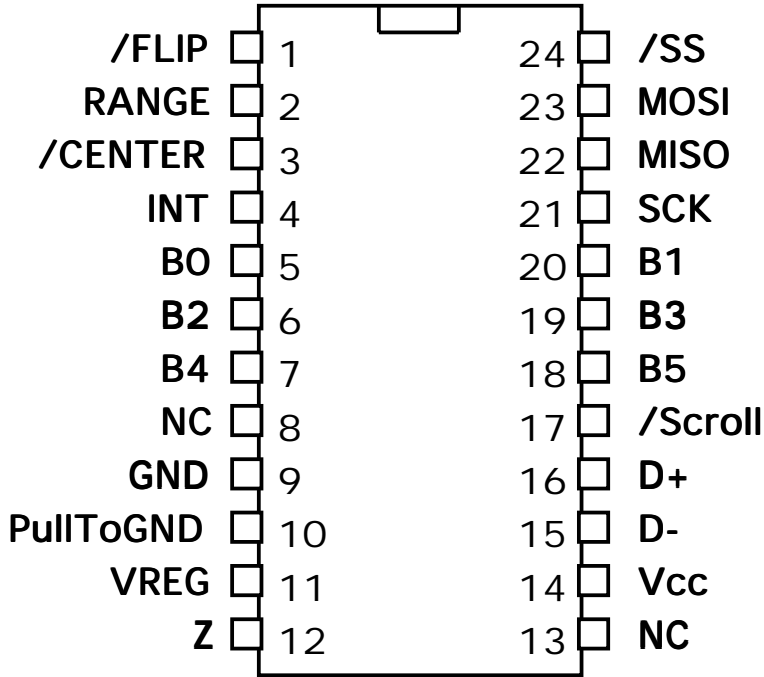

**MouseWarrior24F8-MOD**  
**Module**

**Drawing: BOTTOM VIEW! (Components on the other side)**

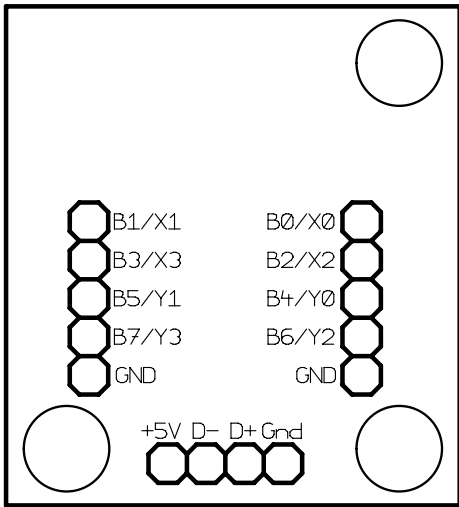

# MW24F8

## 3.1 Axis orientation for MouseWarrior24F8-MOD

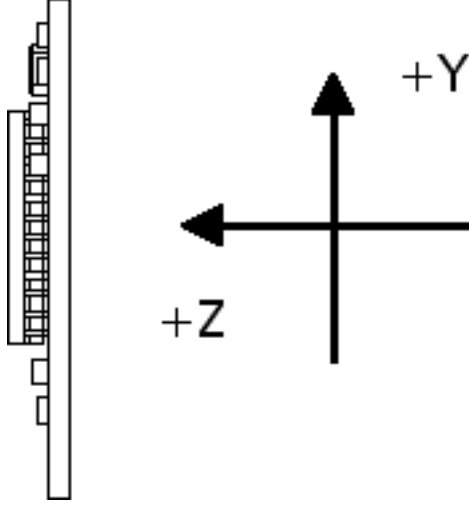
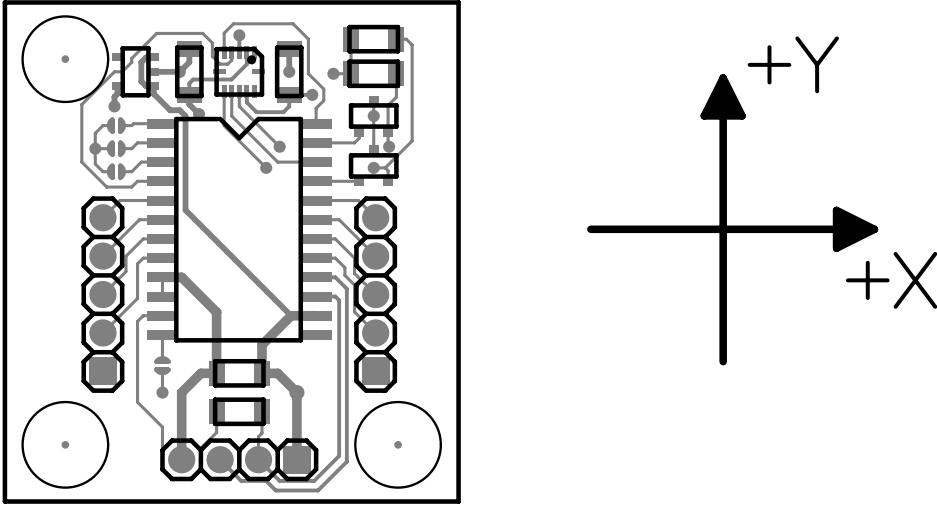

Standard orientation if /FLIP is not pulled low

# MW24F8

## 3.2 Jumper positions for MouseWarrior24F8-MOD

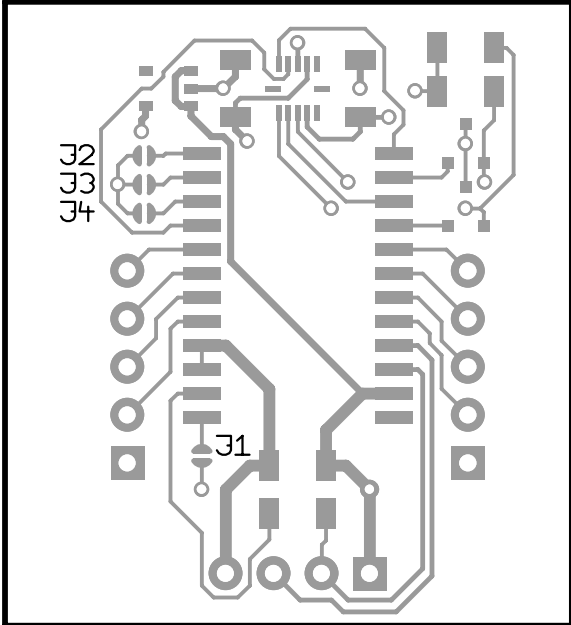

# MW24F8

## 4.0 Pin descriptions MouseWarrior24F8-S

Name	I/O	Type	Pins	Description
D+, D-	I/O	special	16,15	USB differential data lines
B0, B1, B2, B3, B4, B5	I	input, internal Pull Up	5, 20, 6, 19, 7, 18	Button inputs, active low
Z	I	input, internal Pull Down	12	Pull high to disable Z axis from being used for scroll function
/FLIP	I	input, internal Pull Up	1	Pull low to use module in head down position
RANGE	I	input, internal Pull Up	2	Pull low to reduce active sensing range to 25%
/CENTER	I	input, internal Pull Up	3	Pull low to disable the dynamic recentering
/SCROLL	I	input, internal Pull Up	17	Pull low to use Y axis for scrolling function
INT	I	high impedance	4	INT signal from MEMS sensor
SCK	O	external level shift *	21	SCK to MEMS sensor, level adaption required
MISO	I	high impedance	22	SDO from MEMS sensor
MOSI	O	external level shift *	23	SDI to MEMS sensor, level adaption required
/SS	O	open drain	24	CSB signal to MEMS sensor
VREG	O	special **	11	Power for USB D- pull up resistor
PullToGND	I		10	Used during manufacturing, connect to GND
GND		Power supply	9	Ground
Vcc		Power supply	14	Supply voltage
NC			8, 13	do not connect

\*) Level adaption to the 3.3V supply of the MEMS sensor is required.

\*\*) See application circuit for details

## 4.1 Pin descriptions MouseWarrior24F8-MOD

Name	I/O	Type	Description
D+, D-	I/O	special	USB differential data lines
B0, B1, B2, B3, B4, B5	I	input, internal Pull Up	Button inputs, active low
B7	I	input, internal Pull Up	/SCROLL input
GND		Power supply	Ground
Vcc		Power supply	USB supply voltage

# MW24F8

## 4.2 Pin descriptions: SOIC24 package

### D+, D-

Differential data lines of USB. Connect these signals direct to a USB cable. D- requires a pull up resistor, see application circuit for details.

### B0..B5

Inputs for the buttons. Connect contacts closing to ground.

Internal pull up resistors.

### VREG

Supplies 3.3V for the USB D- pull up resistor. Don't use this pin to supply power to external circuitry, it does only supply sufficient current for the pull up resistor.

### INT

Input for the INT signal from the MEMS sensor. This input is used to trigger a wakeup.

High impedance input, connect direct to MEMS sensor.

### SCK

SCK output to the MEMS sensor.

External level adaption to the 3.3V supply of the sensor is required. See application circuit for details.

### MISO

Data input from the MEMS sensor.

High impedance input, connect direct to SDO of the sensor.

### MOSI

Data output to the MEMS sensor.

External level adaption to the 3.3V supply of the sensor is required. See application circuit for details.

### /SS

Enable output to the MEMS sensor.

Open drain output, connect direct to CSB of the sensor.

### Z

Option to disable the use of the Z axis for scrolling. Pull high to disable scrolling by Z axis.

Internal pull down resistor.

### /FLIP

Pull low to enable head down operation. This inverts the direction of X and compensates the negative g force on Z.

Internal pull up resistor.

### RANGE

Pull low to reduce the tilt range used for the mouse cursor control. This allows to use the sensor with smaller maximum angles and prevents the autocalibration function from getting offset by acceleration overshoots.

Internal pull up resistor.

### /CENTER

Pulling this pin low disables the automatic recentering.

Internal pull up resistor.

### /SCROLL

May be used with a button to activate using the Y axis for scrolling. When pulled low X and Y movement will be suppressed and the Y axis data is used for scrolling.

Internal pull up resistor.

### NC

Do not connect, pin may be used in future variants.

### GND

Power supply ground.

### Vcc

Supply voltage.

# MW24F8

---

## 4.3 Pin descriptions: Module

### D+, D-, Vcc, GND

Connect to a USB cable with a type A plug on its other end.

### B0..B5

Inputs for the buttons. Connect contacts closing to ground.

Internal pull up resistors.

### B7

Input for /SCROLL option.

## 4.4 Jumper descriptions: Module

**J1** - Z option, close to disable Z axis for scrolling.

**J2** - /Flip option, close to use the module in head down position.

**J3** - RANGE option, close to reduce the sensor range if the mechanics allows only a limited tilt angle.

**J4** - /CENTER option, close to disable the automatic recentering.

## 5. Device operation

MouseWarrior24F8 works as a standard USB mouse with six buttons and a scroll function. No special drivers need to be installed, it is compatible with the default system drivers.

### 5.1 Low level sensor access

In addition to the mouse function it is possible to directly access the acceleration sensor of MouseWarrior24F8.

The interface for accessing the sensor data is identical to that of the JoyWarrior24F8. The tools for JoyWarrior24F8 do work with MouseWarrior24F8 as well.

Please refer to the JoyWarrior24F8 data sheet for a detailed description of direct access to the sensor.

# MW24F8

## 6. DC Characteristics MW24F8-S / MW24F8-MOD

	Parameter	Min	Max	Units	Remarks
V <sub>cc</sub>	Operating Voltage	4.35	5.25	V	
I <sub>cc</sub>	Operating Supply Current		20	mA	
I <sub>sb</sub>	Suspend mode current (chip)		25	μA	Oscillator off
I <sub>sb</sub>	Suspend mode current (module)		350	μA	Sensor working
R <sub>up</sub>	Pull-up Resistance	8	24	kΩ	
V <sub>ith</sub>	Input Threshold Voltage	40%	60%	V <sub>cc</sub>	
	<b>USB Interface</b>				
V <sub>oh</sub>	Static output high	2.8	3.6	V	15kΩ±5% to GND
V <sub>ol</sub>	Static output low		0.3	V	
V <sub>di</sub>	Differential Input sensitivity	0.2		V	(D+)-(D-)
V <sub>cm</sub>	Differential Input common Mode Range	0.8	2.5	V	
V <sub>se</sub>	Single Ended Transceiver Threshold	0.8	2.0	V	
C <sub>in</sub>	Transceiver capacitance		20	pF	
I <sub>io</sub>	Hi-Z State Data Line Leakage	-10	10	μA	0V < V <sub>in</sub> < 3.3V, Hi-Z State
R <sub>pu</sub>	Bus Pull-up resistance	1.274	1.326	kΩ	1.3kΩ±2% to V <sub>reg</sub>
R <sub>pd</sub>	Bus Pull-down resistance	14.25	15.75	kΩ	15kΩ±5%

## 6.1 AC Characteristics MW24F8-S / MW24F8-MOD

	Parameter	Min	Max	Units	Remarks
F <sub>iclk2</sub>	Internal clock frequency	5.91	6.09	MHz	Clock synchronized to USB
	<b>USB Driver Characteristics</b>				
t <sub>r</sub>	Transition rise time	75		ns	C <sub>Load</sub> = 50pF
t <sub>r</sub>	Transition rise time		300	ns	C <sub>Load</sub> = 350pF
t <sub>f</sub>	Transition fall time	75		ns	C <sub>Load</sub> = 50pF
t <sub>f</sub>	Transition fall time		300	ns	C <sub>Load</sub> = 350pF
t <sub>rfm</sub>	Rise/Fall Time matching	80	125	%	
V <sub>crs</sub>	Output signal crossover voltage	1.3	2.0	V	
	<b>USB Data Timing</b>				
t <sub>drate</sub>	Low Speed Data Rate	1.4775	1.5225	MBit/s	
t <sub>djr1</sub>	Receiver data jitter tolerance	-75	75	ns	To next transition
t <sub>djr2</sub>	Receiver data jitter tolerance	-45	45	ns	For paired transitions
t <sub>deop</sub>	Differential to EOP transition skew	-40	100	ns	
t <sub>eoпр1</sub>	EOP width at receiver	165		ns	Rejects as EOP
t <sub>eoпр2</sub>	EOP width at receiver	675		ns	Accepts as EOP
t <sub>eoпрt</sub>	Source EOP width	1.25	1.50	μs	
t <sub>udj1</sub>	Differential driver jitter	-95	95	ns	To next transition
t <sub>udj2</sub>	Differential driver jitter	-150	150	ns	To paired transition

# MW24F8

## 6.2 Absolute maximum ratings

Storage Temperature	-50°C to +150°C
Ambient Operating Temperature	0°C to +70°C
Supply Voltage on VCC relative to VSS	-0.5V to +7.0V
DC Input Voltage	-0.5V + VCC + 0.5V
Max. Output Current into any Pin	60mA
Power Dissipation	300mW
Static Discharge Voltage (USB and button inputs)	>2000V
Latch-up Current	>200mA
EEPROM write cycles (same byte)	≥1000
EEPROM data retention (at 55°C after 1000 cycles)	≥10 years
Mechanical Shock *	10,000g, ≤100μs 2,000g, ≤1ms
Free fall onto hard surface *	≤1.5m

\*) Maximum shock specs apply for the sensor element only. Using the module in high-g environments will require additional mechanical protection.

## 6.3 Sensor characteristics (MW24F8-MOD)

	Parameter	Min	Typ	Max	Units
S <sub>2g</sub>	Acceleration resolution at ±2g	246	256	266	LSB/g
S <sub>4g</sub>	Acceleration resolution at ±4g	122	128	134	LSB/g
S <sub>8g</sub>	Acceleration resolution at ±8g	61	64	67	LSB/g
Off	Zero-g Offset at T <sub>A</sub> = 25°C	-60		60	mg
Off	Zero-g Offset over lifetime, T <sub>A</sub> = 25°C	-150		150	mg
	Zero-g Offset temperature drift		1		mg/K
NL	Nonlinearity	-0.5%		0.5%	%FS
n <sub>rms</sub>	Output Noise		0.5		mg*√f (filter bandwidth)
/S	Cross Axis Sensitivity, relative between axes			2	%

# MW24F8

## 7. Ordering information

Partname	Order Code	Description	Package
MouseWarrior24 F8	MW24F8-MOD	3D acceleration sensor based mouse complete module	Module
MouseWarrior24 F8	MW24F8-S	3D acceleration sensor based mouse interface chip	SOIC24

The chips listed here are standard products. Customized chips are available on request.

### 7.1 Packaging info

SOIC24 chips come in tubes with 31 chips each. To assure best handling and shipping safety please order the chips in full tubes. Custom chips are produced in multiples of full tubes only. MW24F8-MOD modules come in antistatic boxes or antistatic bags packaged single or bulk.

### 7.2 USB VendorID and ProductID

By default all MouseWarrior chips are shipped with the USB VendorID of Code Mercenaries (\$7C0 or decimal 1984) and a fixed ProductID. On request chips can be equipped with the customers VendorID and ProductID. VendorIDs can be obtained from the USB Implementers Forum <[www.usb.org](http://www.usb.org)> Customized chips are subject to minimum order quantities, contact <[sales@codemerics.com](mailto:sales@codemerics.com)> for details.

Following are the ProductIDs for the MouseWarrior controllers:

MouseWarrior24 F8                      \$1114

ProductIDs are independent of the package type.

See the JoyWarrior data sheet for version information.



# MW24F8

## 9. Package dimensions

### 24 Pin SOIC

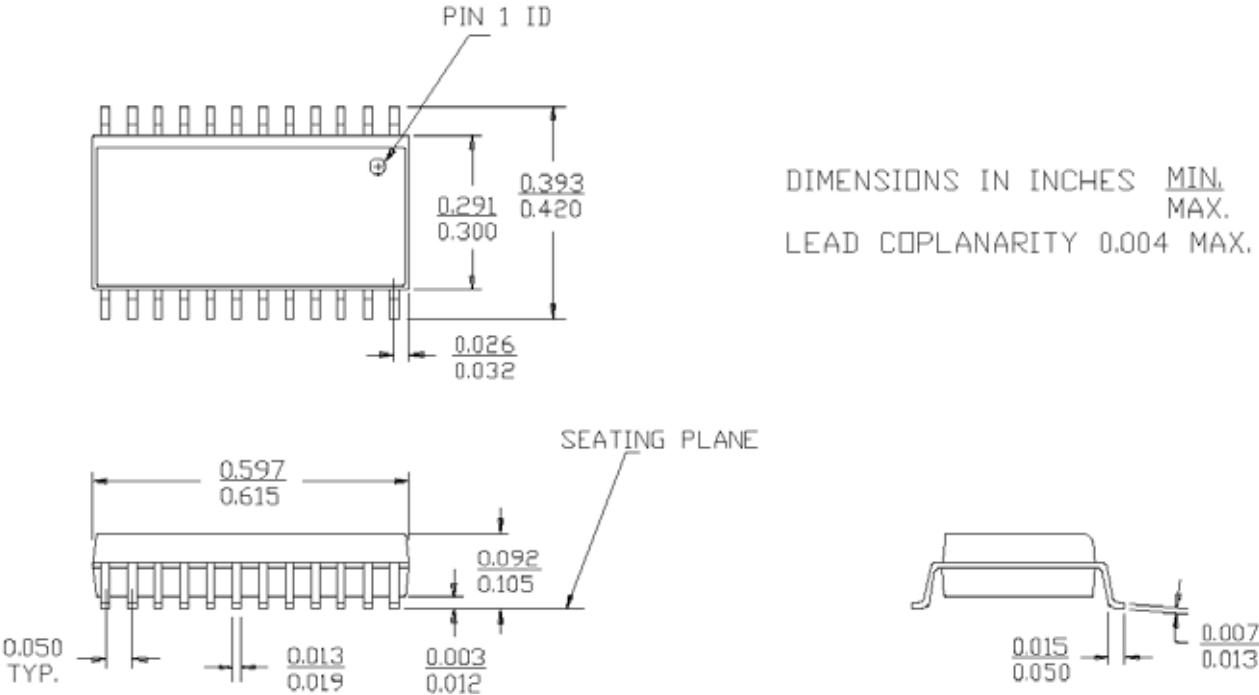

### Module

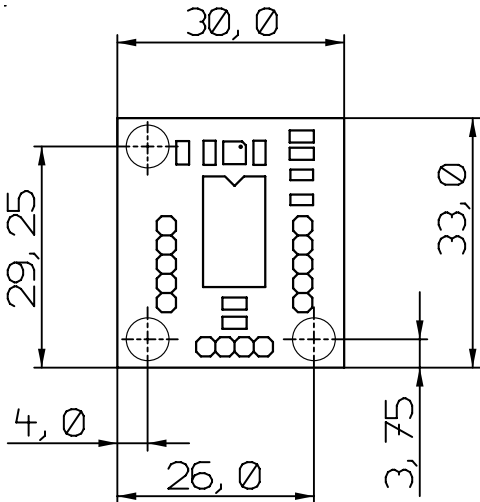

All dimensions in mm  
Mounting holes 2.5mm

# MW24F8

## 10. ESD Considerations

MouseWarrior has an internal ESD protection to withstand discharges of more than 2000V without permanent damage. However ESD may disrupt normal operation of the chip and cause it to exhibit erratic behaviour.

For the typical office environment the 2000V protection is normally sufficient. Though for industrial use additional measures may be necessary.

When adding ESD protection to the signals special care must be taken on the USB signal lines. The USB has very low tolerance for additional resistance or capacitance introduced on the USB differential signals.

Series resistors of 27 $\Omega$  may be used alone or in addition to some kind of suppressor device. In any case the USB 2.0 specification chapter 6 and 7 should be read for detailed specification of the electrical properties.

### 10.1 EMC considerations

MouseWarrior uses relatively low power levels and so it causes few EMC problems.

To avoid any EMC problems the following rules should followed:

- Put the 100nF ceramic capacitor right next to the power supply pins of the chip and make sure the PCB traces between the chips power pins and the capacitor are as short as possible.
- Run the power supply lines first to the capacitor, then to the chip.
- Keep the two USB signal lines close to each other, route no other signal between them. USB uses differential signalling so the best signal quality with lowest RF emission is achieved by putting these lines very close to each other.
- Adding a ferrite bead to the +5V power supply line is advisable.

## 11. Revision history

Please refer to the JoyWarrior main data sheet for the revision history.

Initial shipping version of MW24F8 is V1.0.3.8.

## Legal stuff

This document is ©1999-2008 by Code Mercenaries.

The information contained herein is subject to change without notice. Code Mercenaries makes no claims as to the completeness or correctness of the information contained in this document.

Code Mercenaries assumes no responsibility for the use of any circuitry other than circuitry embodied in a Code Mercenaries product. Nor does it convey or imply any license under patent or other rights.

Code Mercenaries products may not be used in any medical apparatus or other technical products that are critical for the functioning of lifesaving or supporting systems. We define these systems as such that in the case of failure may lead to the death or injury of a person. Incorporation in such a system requires the explicit written permission of the president of Code Mercenaries.

Trademarks used in this document are properties of their respective owners.

Code Mercenaries  
 Hard- und Software GmbH  
 Karl-Marx-Str. 147a  
 12529 Schönefeld OT Grossziethen  
 Germany  
 Tel: x49-3379-20509-20  
 Fax: x49-33790-20509-30  
 Mail: support@codemerics.com  
 Web: www.codemerics.com

HRB 16007 P  
 Geschäftsführer: Guido Körber, Christian Lucht